



Surface Mount Installation
Shown with optional Extender Kit
Pull Station w/ Backbox not included



Semi-Flush Mount Installation
Pull Station not included

NATIONAL TIME's Station Cover is a rugged polycarbonate cover used to help protect manual pull stations and other devices from false alarms, vandalism, dust and weather. It is available in a variety of configurations to satisfy most applications.

This cover meets the requirements of the Americans with Disabilities Act (ADA). Specifically, it has been tested by UL for compliance with the 5lb. pull force requirement. In addition, the total depth of the unit when mounted is less than the required 4 inches. What's more, it can be operated easily with one hand without having to grasp and when opened will not obstruct the use of the pull station, an important requirement for ADA applications.

Units with the optional alarm module can be used as false alarm deterrents in applications such as schools, libraries, etc. When installed, the alarm module will emit a piercing scream when the cover is opened. This startling noise will help to deter most malicious pranksters and to indicate the location of the problem.

A weather proof kit is available which will allow the unit to be installed in outdoor applications. This optional kit will provide NEMA 3R protection to the device.

FEATURES

- **ADA Compliant**
- **UL Listed**
- **Tough Polycarbonate Construction**
- **UV Stabilized**

OPTIONAL FEATURES

- **Alarm Module w/ Siren**
- **Extender Kit**
- **Weather Kit w/ Gaskets**
- **Backplate for Rough Surfaces**

Assembly Diagram

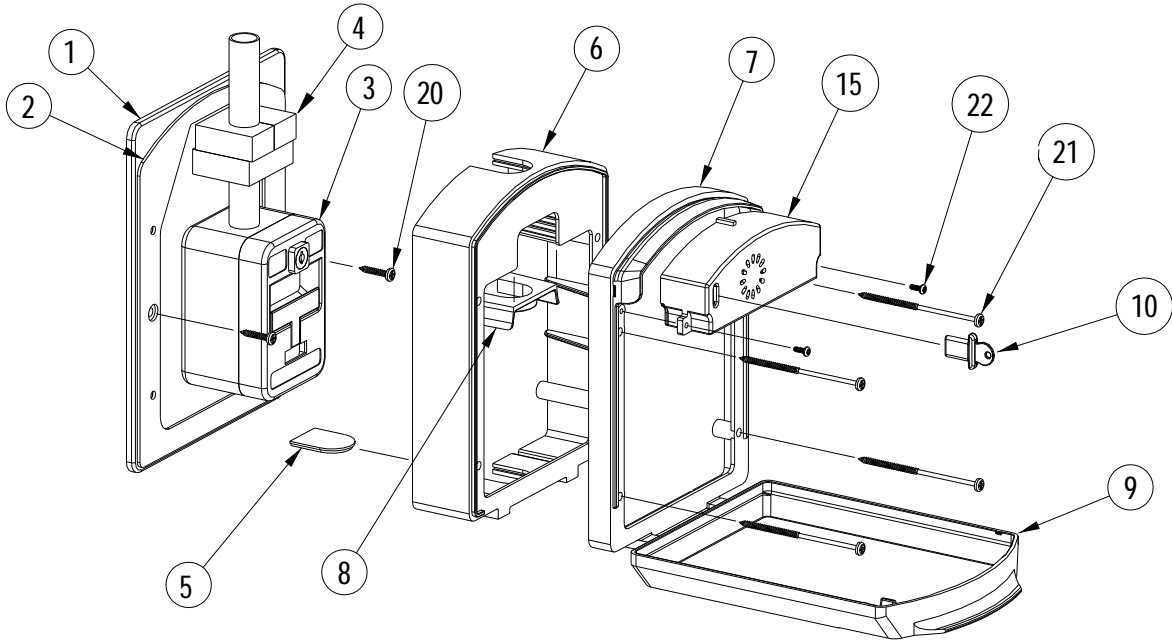

Ordering Information

Part No.	Description	Item No.	Qty.
ST-BKP01	Backplate Kit		
	Backplate	1	1
	Screw, #10 Type A, 1" Phillips round head	20	2
ST-XTR01	Extender Kit		
	Extender	6	1
	Conduit Block Plate	5	2
	Compression Plate	8	1
	Screw, #10 Type A, 4" Phillips round head	21	4
ST-WPK01	Weather Proof Kit		
	Conduit Gasket	4	2
	Gasket, Flat	2	1
ST-FRC01	Front Cover Kit		
	Frame	7	1
	Front Cover	9	1
	Screw, #10 Type A, 1.75" Phillips round head	n/a	4
ST-ALM01	Alarm Module Kit		
	Alarm Module	15	1
	Silencer Key	10	1
	Screw, 6-32 x 3/8", Phillips pan head	22	2

Item 3: Pull Station ordered separately