

Hand Replacement Instructions

Self Regulating Synchronous Series

These instructions describe how to replace hands on an existing NATIONAL TIME self regulating synchronous clock manufactured between May 1999 and November 2000. The manufacturing date is stamped on the rear plate of the movement. The date code is a 4 digit number representing the month and year of manufacture (i.e. 0599 thru 1100)

Recommended Tools:

Ohm meter with clip type leads

1/4" socket (1/4" drive thin walled socket works best) with extension or driver handle for Surface Mounted Clocks.

Foamed box clock holder supplied with hand shipment, or substitute large towel.

STEP 1: Remove power for clock circuit.

STEP 2: Remove clock from wall and disconnect wiring.

Steps 3-7 describe how to locate the 6:01 position of the clock movement. Internal to the clock mechanism, there exists a leaf-switch which is activated by the switch actuator arm from approximately 5:50 to 6:40 (See Figure 1). This switch interrupts the power to the reset coil for this duration. This switch activation may be seen visually after removal of the dust cover, or by measuring the continuity with an ohm meter.

STEP 3: Insert Clock face down in foam packing material or form a towel into 'doughnut' shape to support clock glass and case face down on a flat surface (Figure 2).

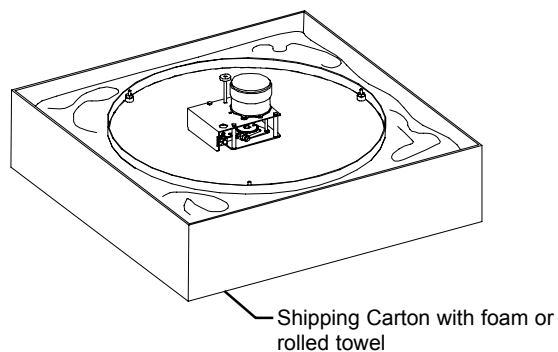

Figure 2

There is a 'click' each time the ratchet internal to the clock mechanism passes the hour.

STEP 6: After the switch opens, continue turning the setting stem counterclockwise until the movement 'clicks' past the hour position.

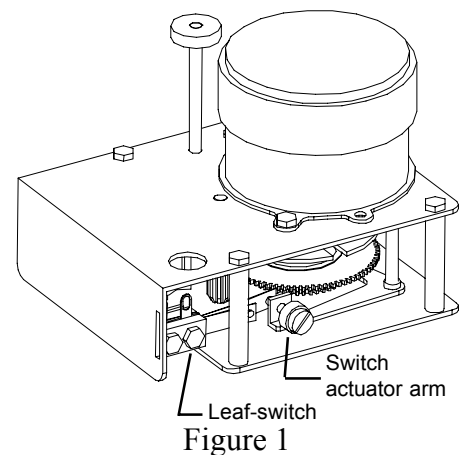

Figure 1

STEP 4: Clip the Ohm meter probes to clock leads as shown in figure 3. Wire colors may vary with clock model. With the switch closed, the meter should read approximately 2K Ohms (120VAC) or 80 Ohms (24VAC).

STEP 5: Turn setting stem counterclockwise (which will advance the clock) watching the ohm meter reading. When the switch opens, the ohm meter will read maximum resistance.

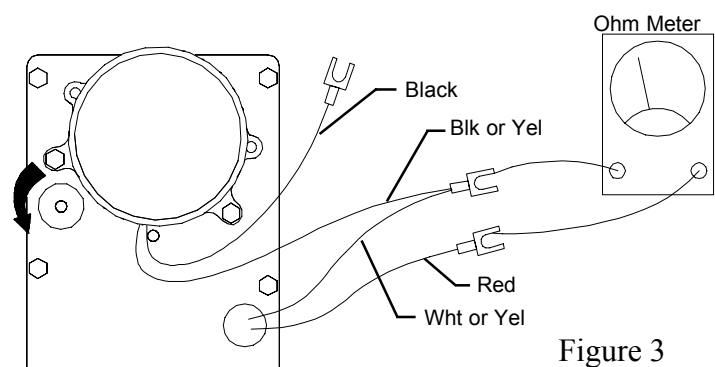

Figure 3

STEP 7: Turn the setting stem clockwise (Fig 4) until the ratchet internal to the movement prevents further rotation. This will back the minute hand to one minute past the hour. The meter should still read 'open'.
The movement is now at 6:01.
 (Hands may or may not coincide)
STEP 8: Disconnect ohm meter.

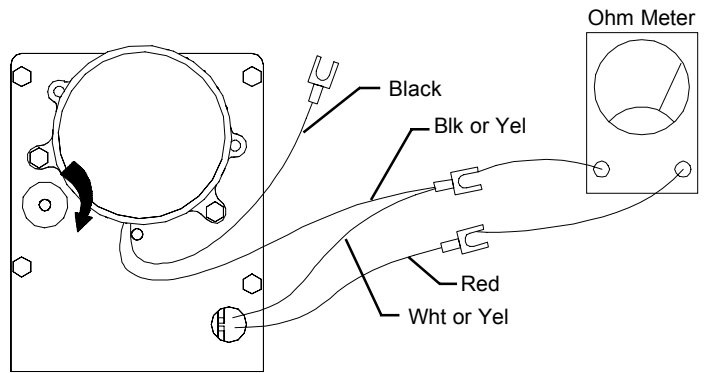

Figure 4

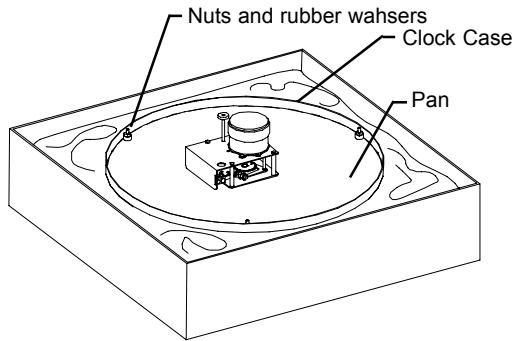

Figure 5

Steps 9&10 Describe Clock Case Disassembly

STEP 9: Using 1/4" socket wrench, remove the (3) nuts holding the clock case and glass. Refer to Figure 5 if necessary.

STEP 10: Remove rubber washers. Washers are removed easily by reaching around clock case with fingers and forcing the glass and clock pan away from clock case.

The following steps describe removal of existing hands:

STEP 11: While holding the clock by the movement in one hand remove the sweep second hand.

The sweep second hand is one of two types:

Threaded- If the sweep second shaft is silver, the sweep second hand may be removed by unscrewing counter clockwise.

Press Fit Double 'D' - If the sweep second shaft is white, the sweep second hand simply pulls off.

STEP 12: At this step, the minute hand should be 1 minute past the hour. To remove the minute hand, rotate the hand counterclockwise against the stop while pulling. **Do not rotate the hand clockwise or the movement will no longer be located at 6:01.**

STEP 13: The hour hand is a force fit and may simply be pulled straight off of the hour shaft.

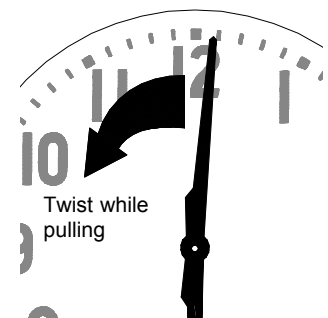

Hour Hand Replacement:

STEP 14: The hour hand is a force fit and must be pushed straight on the hour shaft **pointing directly at the 6 on the dial**.

Push the hand on until approximately 1/32" of the hour shaft sticks through the hand bushing. Make sure the hand bushing does not contact the threaded bushing. Form the hand to the correct shape by pushing with the thumb and forefinger near the hub of the hand. See Figure 6. The tip and tail of the hand should slope toward the dial with the tip approximately 1/8" from the dial.

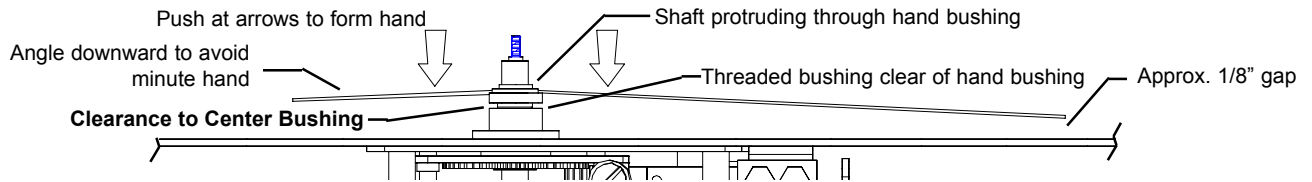

Figure 6

Minute Hand Replacement:

STEP 15: The minute hand may now be replaced. It is important not to advance the clock movement clockwise while attaching the hand. Lightly place the hand on the shaft at approximately 5 minutes after the hour. (See Figure 7.)



Figure 7

Rotate the minute hand counterclockwise while pressing the hand on the shaft. Stop when the hand is located at the 6:01 position. If you accidentally go beyond 6:01, simply keep turning counterclockwise and lift the hand off and start over at 5 minutes after the hour. **Do not rotate the hand clockwise as this will change the location of the minute shaft.**

STEP 16: Form the minute hand as shown in figure 8. The setting stem may be rotated at this time to make sure the hands do not collide or scrape dial when advancing the clock movement.

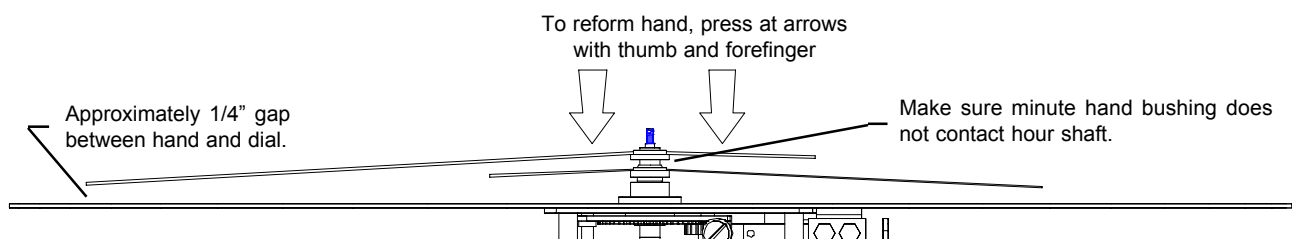

Figure 8

Sweep Second Hand Replacement:

STEP 17a: If the sweep second hand is of the threaded type, simply thread on the hand by rotating clockwise until snug. The location of the second hand is unimportant.

STEP 17b: If the sweep second hand is of the force fit type, simply align the flats with the flats on the shaft and press into place.

STEP 18: Form the second hand as shown in figure 9. The setting stem may be rotated at this time to make sure the hands do not collide when advancing the clock movement.

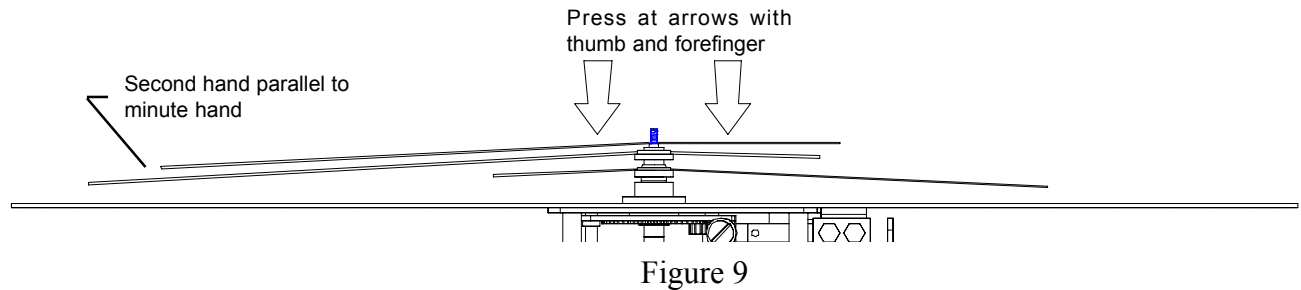

Figure 9

Reassemble Clock Case:

STEP 19: Carefully place clock movement and dial back onto clock case aligning the studs with the pan notches.

STEP 20: Replace rubber washers and nuts onto threaded studs. Tighten nuts until the rubber washer compresses slightly. **Do not over tighten nuts, they only need to be snug.**

Hang Clock back in place:

STEP 21: Reattach wires to clock motor and reset coil. Hang clock onto hanger bracket.

STEP 22: Apply power to clock circuit. Clocks will automatically correct to the right time after the next 6:00 reset from the master clock.